



**HANDLE·IT<sup>®</sup>**



# **STRAPPING EQUIPMENT**

[www.handleitinc.com](http://www.handleitinc.com)

# VERTICAL STRAPPING MACHINE

Model: **PSM-FA-VCA**



## Standard Machine Features:

- Robust strapping head for polypropylene (PP) strap with easy to access components.
- Easily accessible strapping threading with touch screen adjustable tension.
- Thermo-fusion strapping seal with electronically adjustable temperature.
- Solid steel frame structure built for working in extreme environments such as construction.
- Touch screen to adjust up to 30 settings
- Machine meeting CE safety standards (2006/42/CE 2014/30/UE 2014/35/CE-BT).

\*\*Powered Conveyor is required with this unit. -Sold separately-

## Applications:

The Handle-It Vertical Strapper can operate as a stand-alone machine or may be integrated in an automatic line.



Manufacturing



Food & Beverage



Pharmaceuticals



Construction Materials

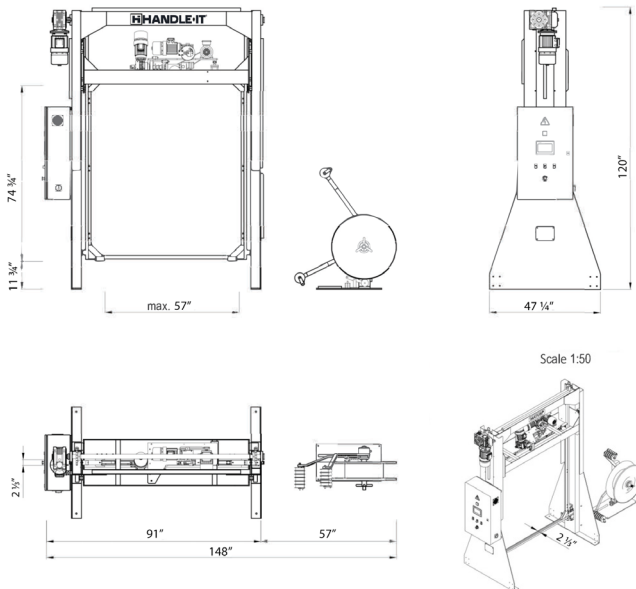

## Standard Diagram

Outfit to a Wide Range of Applications

## Machine Specifications:

Min/Max. Load Height	-with lance: 300mm/1900mm -with closed arch: 100mm/1900mm
Max. Load Width	1400mm
Min. Combination of Load	W400mm x H1000mm - 55lbs
Productivity	60-70 pallets/hour



# HORIZONTAL STRAPPING MACHINE

Model: PSM-FA-HCA

## Standard Machine Features:

- Self-adjusting floating strapping head
- Revolutionary dynamic arch system
- Lighted warning system around the machine
- 10" Touch-screen HMI
- Thermofusion strapping seal
- 100% electric operation; no pneumatic or hydraulic parts

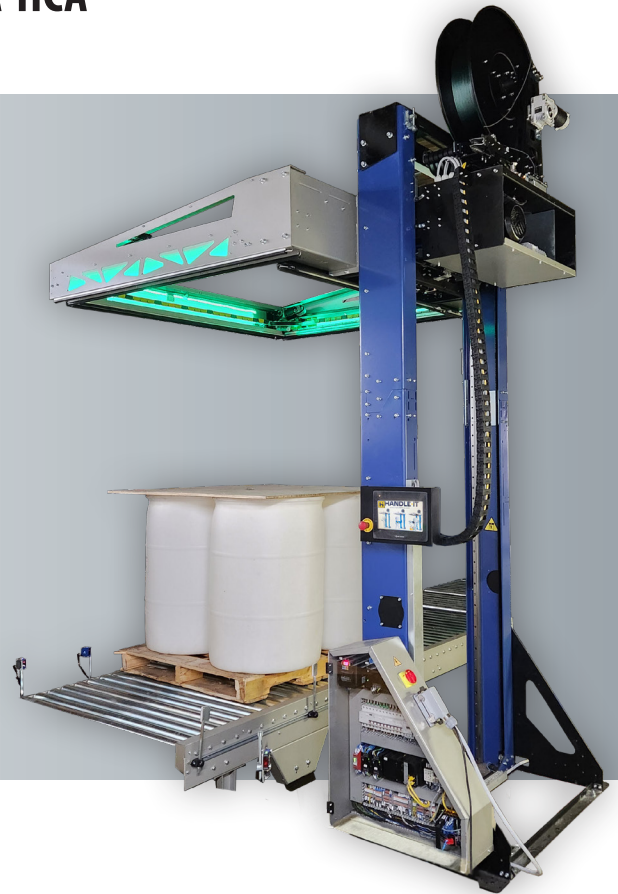

## Applications:

The Handle-It Horizontal Strapper can operate as a stand-alone machine or may be integrated in an automatic line.



Fruits & Vegetables



Construction Materials



Barrels



Furniture

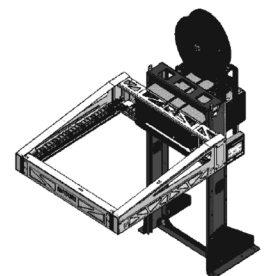
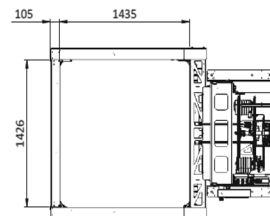
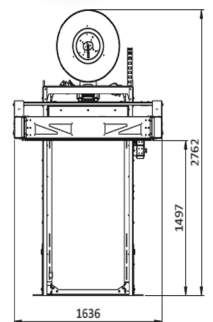
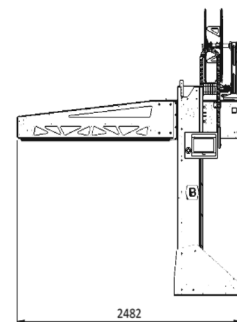

## Machine Specifications:

Min/Max. Load Height	110mm/1400mm (custom up to 2700mm)
Min/Max. Load Width	300mm/1300mm
Min/Max. Load Length	300mm/1300mm
Productivity	2-Straps: 90 Pallets/Hr 5-Straps: 80 Pallets/hr

## Standard Diagram

Outfit to a Wide Range of Applications

Handle It, has been dedicated to providing the market with competitively priced, highquality products since 1976. Handle It continues to expand on the current line of products as well as develop custom engineered solutions to meet customer's specific applications. Handle It is represented by a network of dealers both nationally and internationally.

## **Our Brand Promise**

"Handle It with Confidence: Delivering quality packaging equipment and warehouse guarding solutions. We promise exceptional support, ensuring your efficient operations."

## **Why Choose Handle-It?**

We prioritize your end-of-line packaging. From the initial consultation to project completion, we walk you through each step with clear communication and expert guidance. We value our Dealers and provide guidance in sales and service training ensuring they are equipped with all the information necessary to meet their customer's needs.

For customized projects, we take the time to thoroughly understand your goals, offer personalized advice, and recommend the best possible solutions to ensure an outcome that exceeds your expectations. Our dedication to quality and customer satisfaction is what sets us apart.

## **Equipment Support & Service**



Handle It, Inc. stands behind the equipment we sell and supply. We stock replacement parts in our Milwaukee, WI warehouse, so we can ensure your operations are up and running as quickly as possible.



*Our technical support team is available during business hours to walk customers through any issues or questions.*

Contact Us Today:  
Phone: 800-236-1080  
[www.handleitinc.com](http://www.handleitinc.com)  
[sales@handleitinc.com](mailto:sales@handleitinc.com)

